

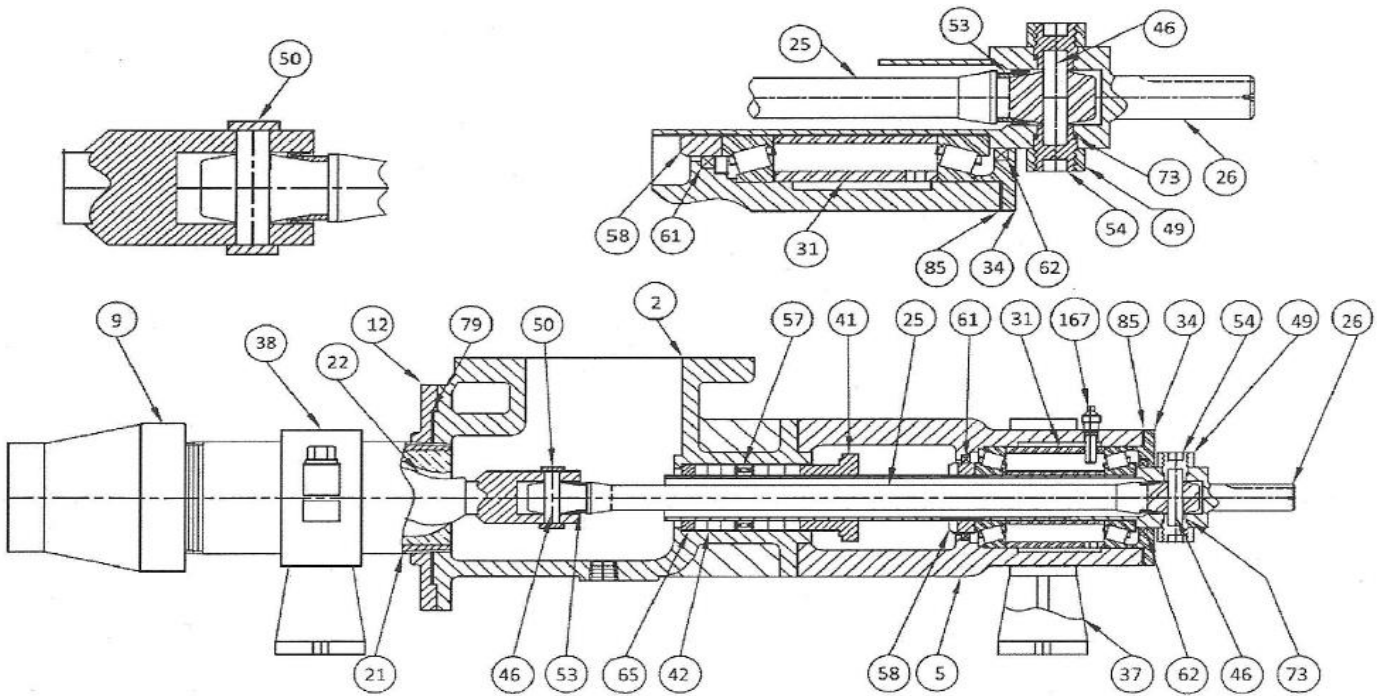

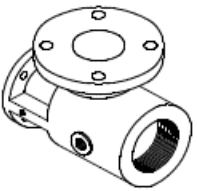







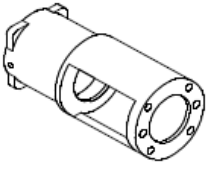

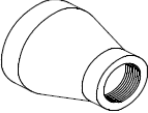



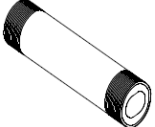

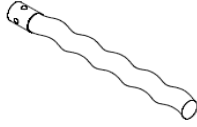



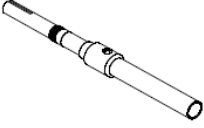

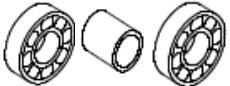

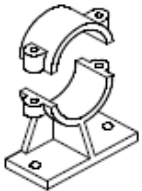

**L-FRAME MODEL
GWL12(H) ASSEMBLY**

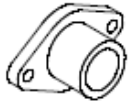

ITEM #	DESCRIPTION		ITEM #	DESCRIPTION	
2	SUCTION HOUSING		45	ROTOR PIN	
5	BEARING HOUSING		46	SHAFT PIN	
9	REDUCER		49	SHAFT COLLAR	
12	ADAPTOR FLANGE		50	ROTOR BAND (PIN RETAINER)	
21	STATOR		53	CONNECTING ROD WASHER	

L-FRAME MODEL GWL12(H) ASSEMBLY(CONTINUED)

ITEM #	DESCRIPTION		ITEM #	DESCRIPTION	
22	ROTOR		54	DRIVE PIN RETAINER SCREW	
25	CONNECTING ROD		57	LANTERN RING (SHOWN AS 2-PIECE TEFLON)	
26	DRIVE SHAFT		58	BEARING LOCK NUT	
31	BEARING ASSEMBLY		61	RADIAL GREASE SEAL	
34	BEARING COVER PLATE		62	THRUST GREASE SEAL	
37	PUMP SUPPORT		65	PACKING WASHER (PACKING GLAND INSERT)	
38	STATOR SUPPORT		73	RETAINING SCREW WASHER	
41	PACKING GLAND		79	ADAPTOR FLANGE GASKET	
42	PACKING SET		85	COVER PLATE GASKET	
			167	GREASE FITTING	

MATERIALS OF CONSTRUCTION

C = CAST IRON/CARBON STEEL
S = STAINLESS STEEL

Q = BUNA NITRILE
B = EPDM

F = VITON®
R = NATURAL RUBBER

NOTE: FOR MECHANICAL SEAL PUMPS, ITEM #'S 41, 42, 57, & 65 TYPICALLY NOT INCLUDED.
FOR PUMP SIZES 3GWL12 & 2GWL12H, (2) STATOR SUPPORTS (ITEM #38) ARE REQUIRED.